

Level :	<i>1</i>	Menu :	<i>NucleoLab</i>	Character :	<i>Korben</i>
Inventory item :	<i>Gun</i>	<i>3 cards on enemies</i>			
Enemies :	<i>Lab scientists</i>	<i>Mutant of the lab</i>	<i>Nucleolab guardians</i>		

Mission : *Korben must get into the Nucleolab to find the cellular reconstruction laboratory. Once there he must reactivate Leeloo's materialisation using the genetic card.*

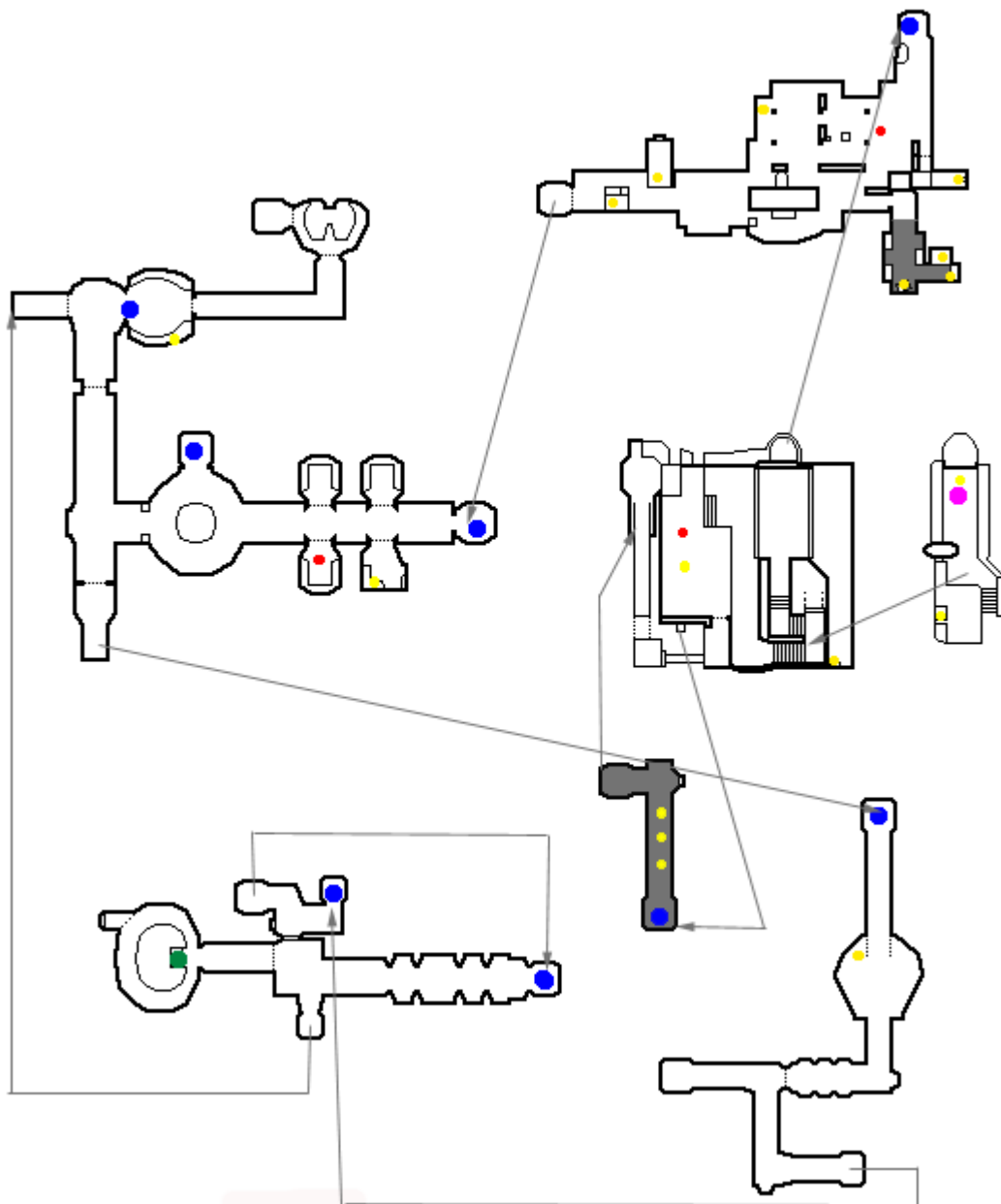





- Start
- Arrival
- Inventory Item
- Checkpoint
- Secret
- Card on enemy



Level :	2	Menu :	<i>N,Y,P,D,</i>	Character :	<i>Leeloo</i>
----------------	---	---------------	-----------------	--------------------	---------------

Inventory item :			
Enemies :	<i>Cop with truncheon</i>	<i>Flying Cop</i>	<i>Hand fighting Mangalore</i>

Mission : *Korben has been arrested by the police. Leeloo must get into the police station and free Korben who is held in a cell.*



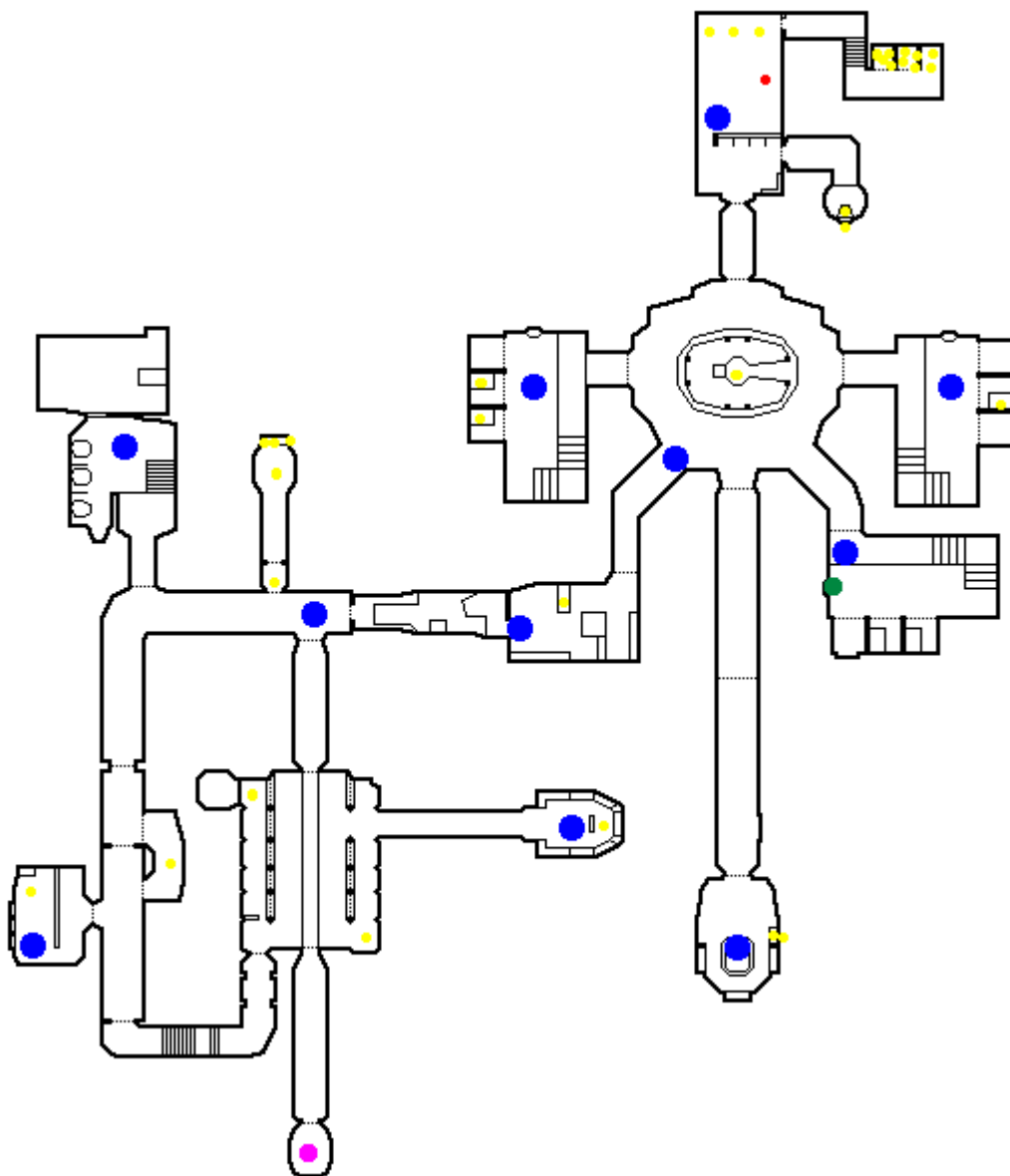



 Start	 Arrival	 Inventory Item	 Checkpoint	 Secret
		 Card on ennemy		



Level :	<i>2-bis</i>	Menu :	<i>N,Y,P,D,</i>	Character :	<i>Leeloo</i>
----------------	--------------	---------------	-----------------	--------------------	---------------

Inventory item :			
Enemies :	<i>Cop with truncheon</i>	<i>Flying Cop</i>	<i>Hand fighting Mangalore</i>





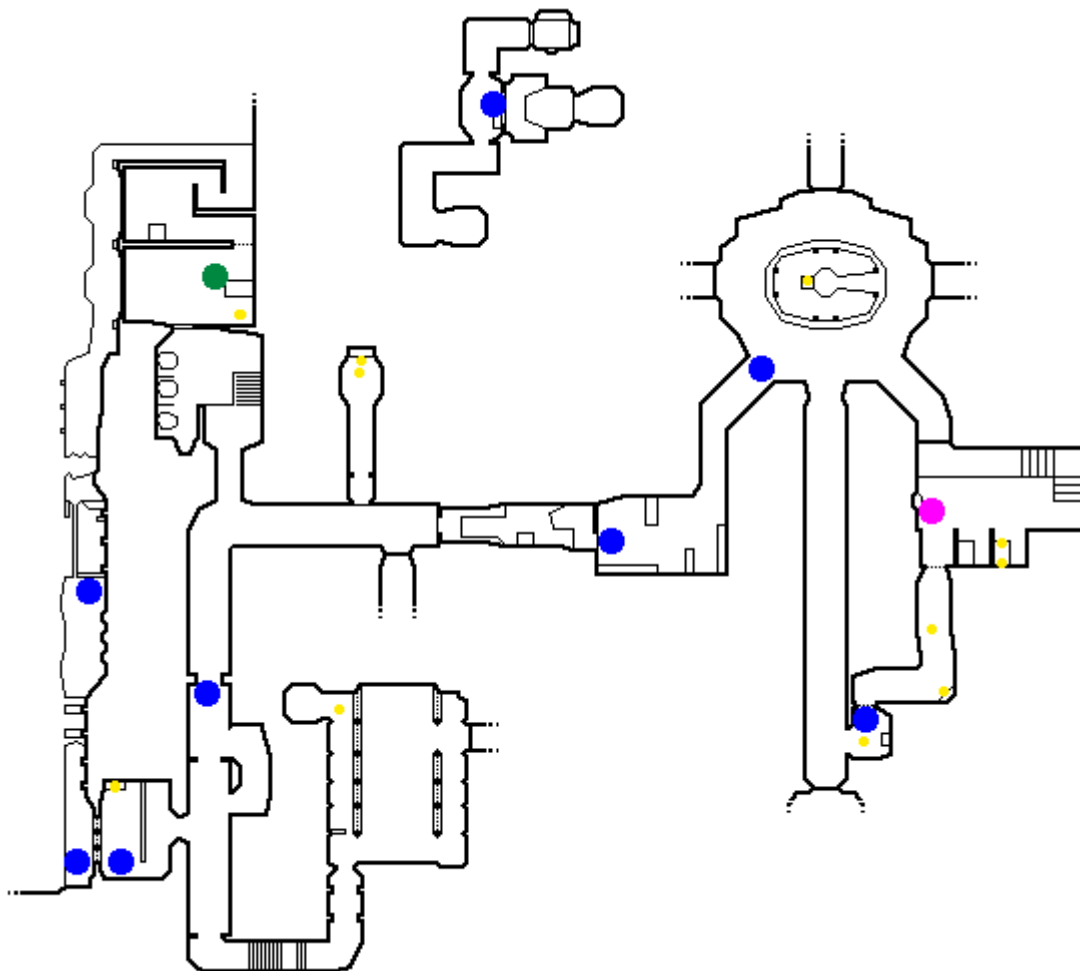

Mission : *Leeloo has freed Korben, but the police station is now in a state of alert. Find a way out in less that 1 minute and 30 seconds otherwise they will both be trapped.*

 Start	 Arrival	 Inventory Item	 Checkpoint	 Secret
		 Card on ennemy		



Level :	3-1	Menu :	Cornelius	Character :	Korben
Inventory item :	Electrogun		4 cards on enemies		Fire activator
Enemies :	Black cop with gun		White cop with gun		Zorg's man with gun

Mission : Father Cornelius holds the secret to the absolute weapon against Evil. Leelo must find the Earth activator located in his apartment. Korben must bring the Fire activator to the priest's apartment.



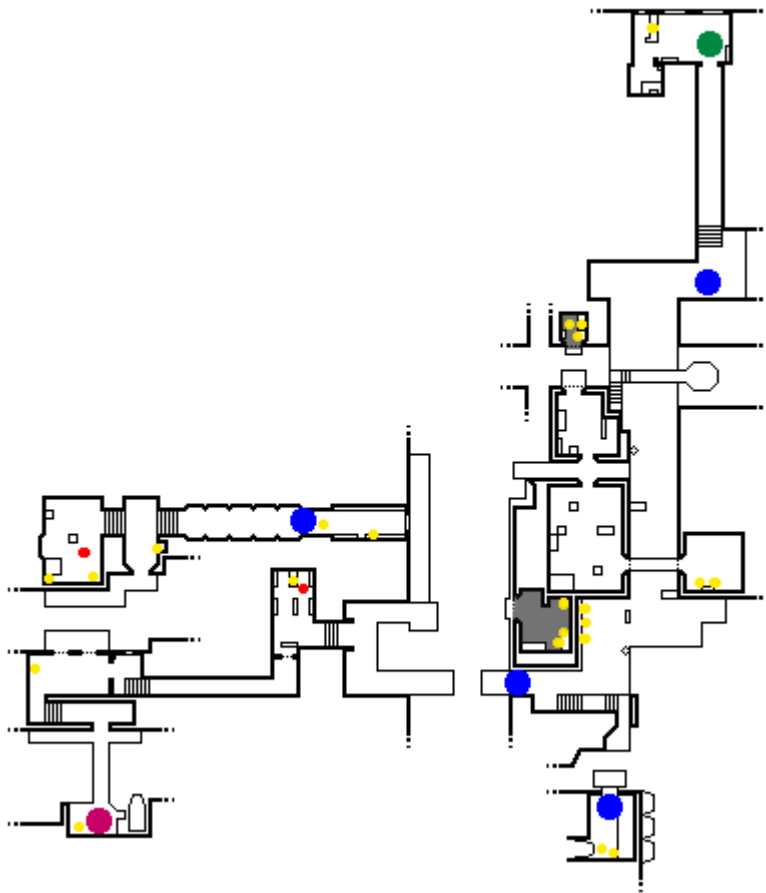



 Start	 Arrival	 Inventory Item	 Checkpoint	 Secret
		 Card on enemy		



Level :	3-2	Menu :	Cornelius	Character :	Leeloo
---------	-----	--------	-----------	-------------	--------

Inventory item :	Earth Activator	2 cards on enemies	
Enemies :	Cop with truncheon	White Zorg's man	Black Zorg's man

Mission : *Father Cornelius holds the secret to the absolute weapon against Evil. Leeloo must find the Earth activator located in his apartment. Korben must bring the Fire activator to the priest's apartment.*

 Start	 Arrival	 Inventory Item	 Checkpoint	 Secret
		 Card on enemy		

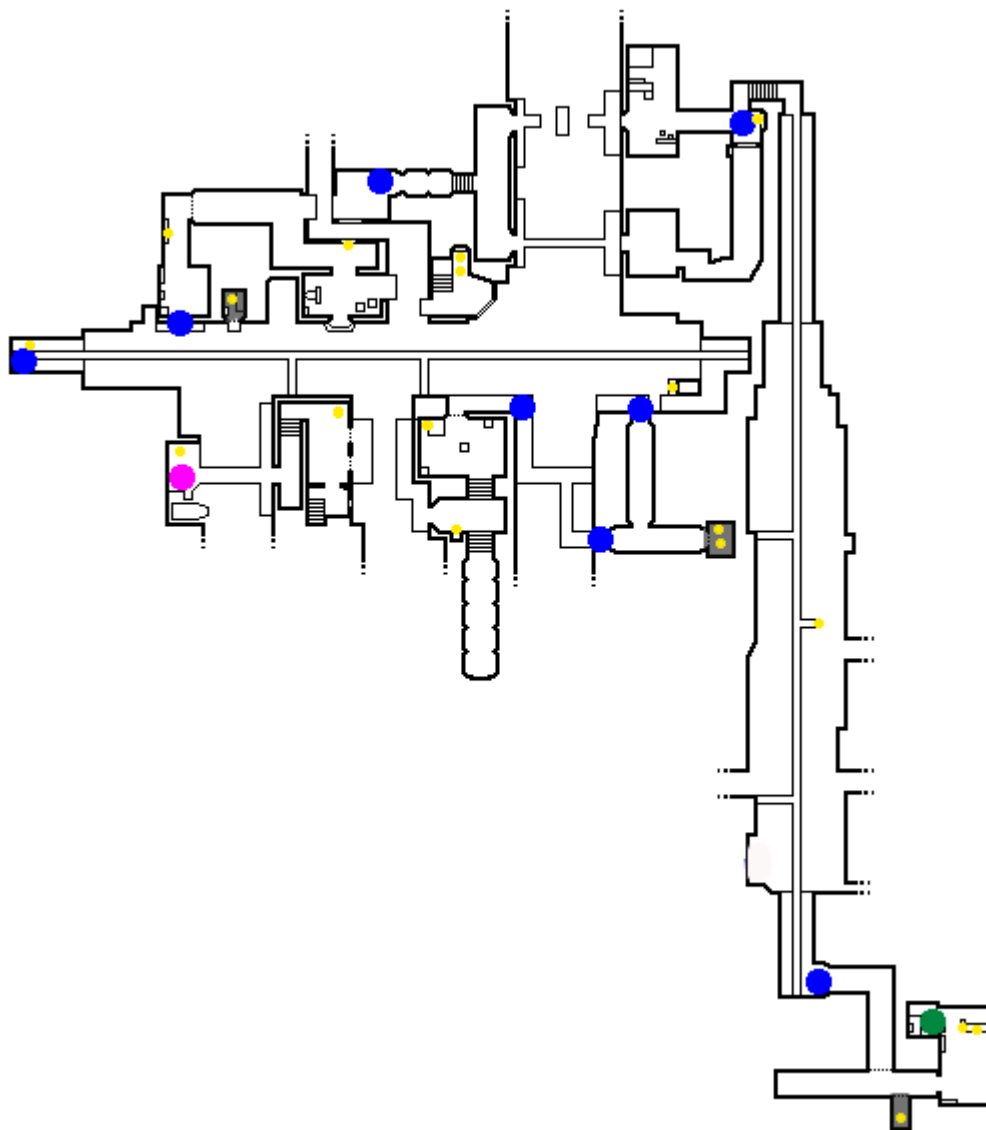

Level :	4-1	Menu :	Zorg's HQ	Character :	Korben
---------	-----	--------	-----------	-------------	--------

Inventory item :	ZF1	Fhloston tickets	
Enemies :	Zorg's man with gun	Spider	Medusa

Mission : Zorg, absolute evil's ally, has captured Cornelius. Korben and Leelo must attack his headquarters in order to free their friend. On the way Leelo must find the tickets to Fhloston Paradise and Korben must deactivate the headquarters' security system by neutralising the central computer.



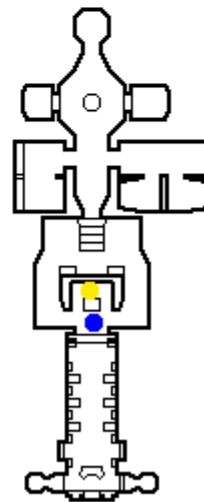
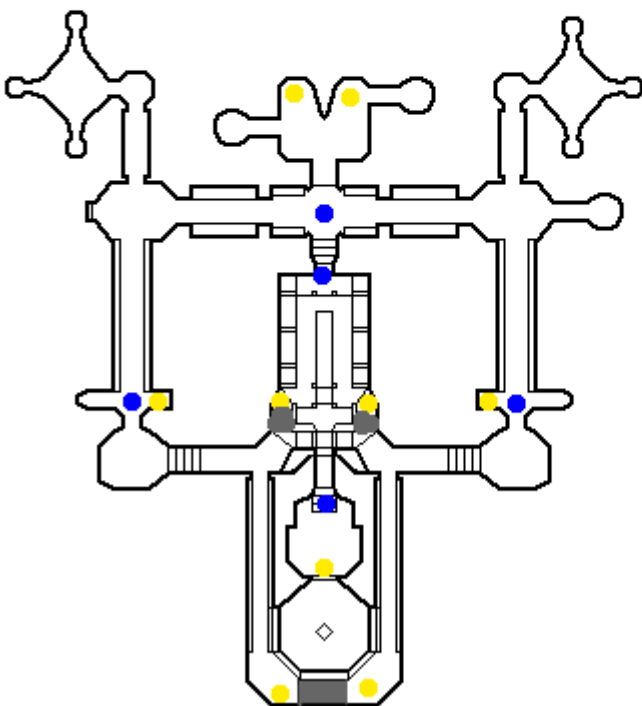
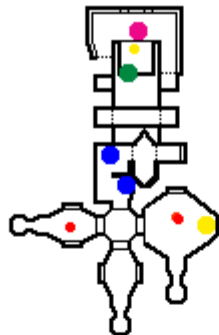



- Start
- Arrival
- Inventory Item
- Checkpoint
- Secret
- Card on ennemy



Level :	<i>4-2</i>	Menu :	<i>Zorg's HQ</i>	Character :	<i>Leeloo</i>
----------------	------------	---------------	------------------	--------------------	---------------

Inventory item :	<i>1 card on ennemi</i>		
Enemies :	<i>Spider</i>	<i>Big white robot</i>	<i>Black Zorg's man</i>





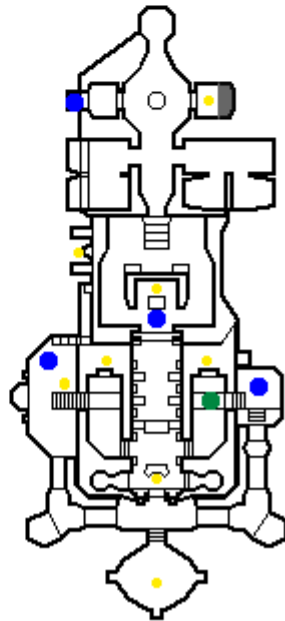
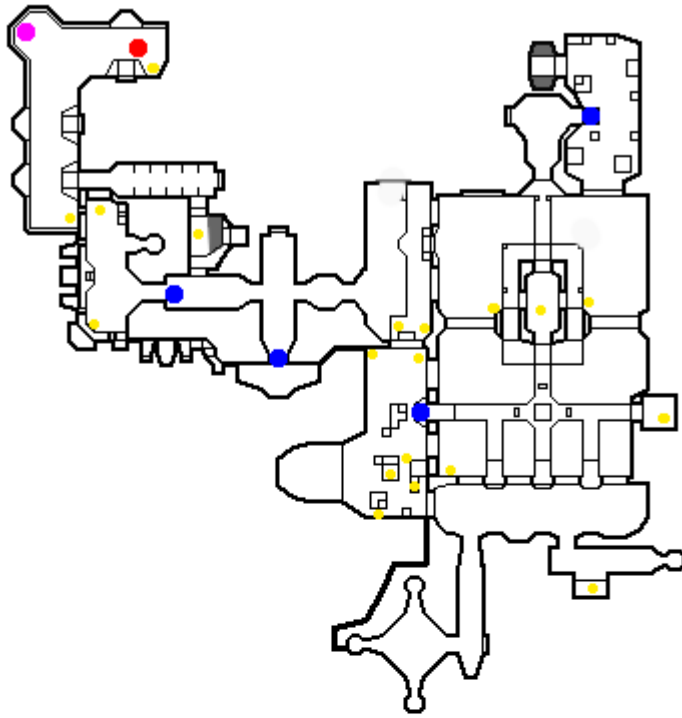

Mission : *Zorg, absolute evil's ally, has captured Cornelius. Korben and Leeloo must attack his headquarters in order to free their friend. On the way Leeloo must find the tickets to Fhloston Paradise and Korben must deactivate the headquarters' security system by neutralising the central computer.*

 Start	 Arrival	 Inventory Item	 Checkpoint	 Secret
 Card on enemy				



Level :	5	Menu :	Escape from Zorg's HQ	Character :	Leeloo
Inventory item :					
Enemies :					





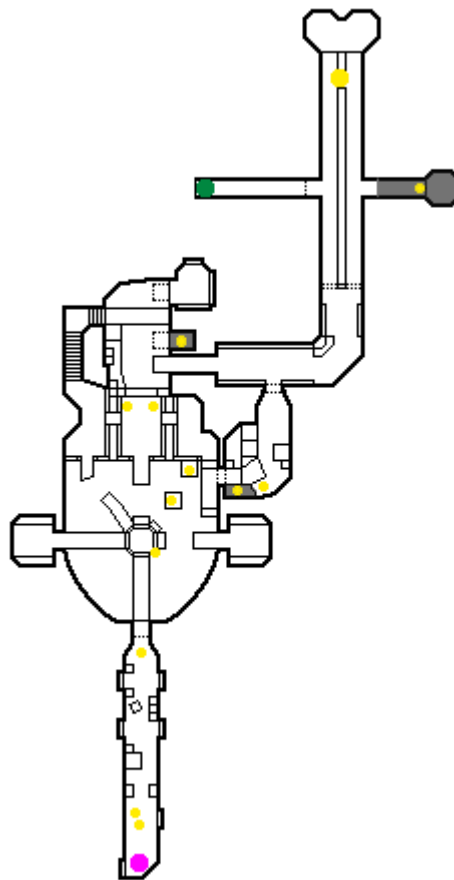

Mission : *By neutralising the central computer, Korben has set off a chain reaction that will destroy Zorg's headquarters. Fortunately for him, he is out of danger but Leeloo must find her way out of the building!*

 Start	 Arrival	 Inventory Item	 Checkpoint	 Secret
		 Card on ennemy		



Level :	6-1	Menu :	Depths of NY	Character :	Korben
Inventory item :	Electrogun	ZF1	2 cards on ennemies		
Enemies :	Black cop with gun	Mangalore with machine gun	Mangalore with 2 guns		

Mission : The New York police are after Leeloo and Korben who have taken refuge in the depths of New York. They must both find ammunition, weapons and other items they need to get out of the area before they are captured.

 Start	 Arrival	 Inventory Item	 Checkpoint	 Secret
		 Card on enemy		

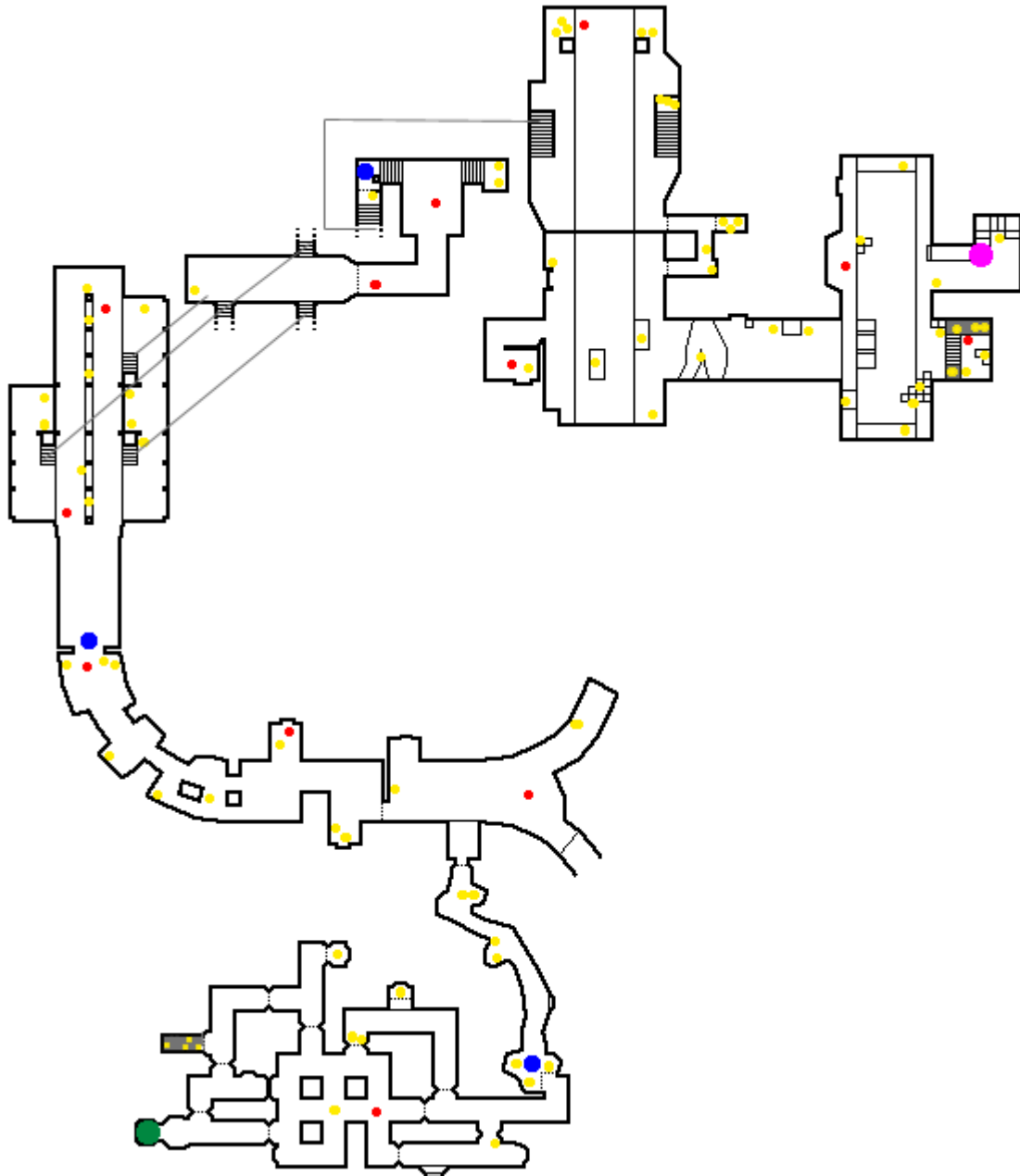

Level :	6-2	Menu :	<i>Depths of NY</i>	Character :	<i>Leeloo</i>
Inventory item :	<i>2 cards on ennemies</i>		<i>Part for the taxi</i>		<i>Leeloo Multipass</i>
Enemies :	<i>Cop with truncheon</i>		<i>Hand fighting Mangalore</i>		<i>Green sewers monster</i>

Mission : *The New York police are after Leeloo and Korben who have taken refuge in the depths of New York. They must both find ammunition, weapons and other items they need to get out of the area before they are captured.*



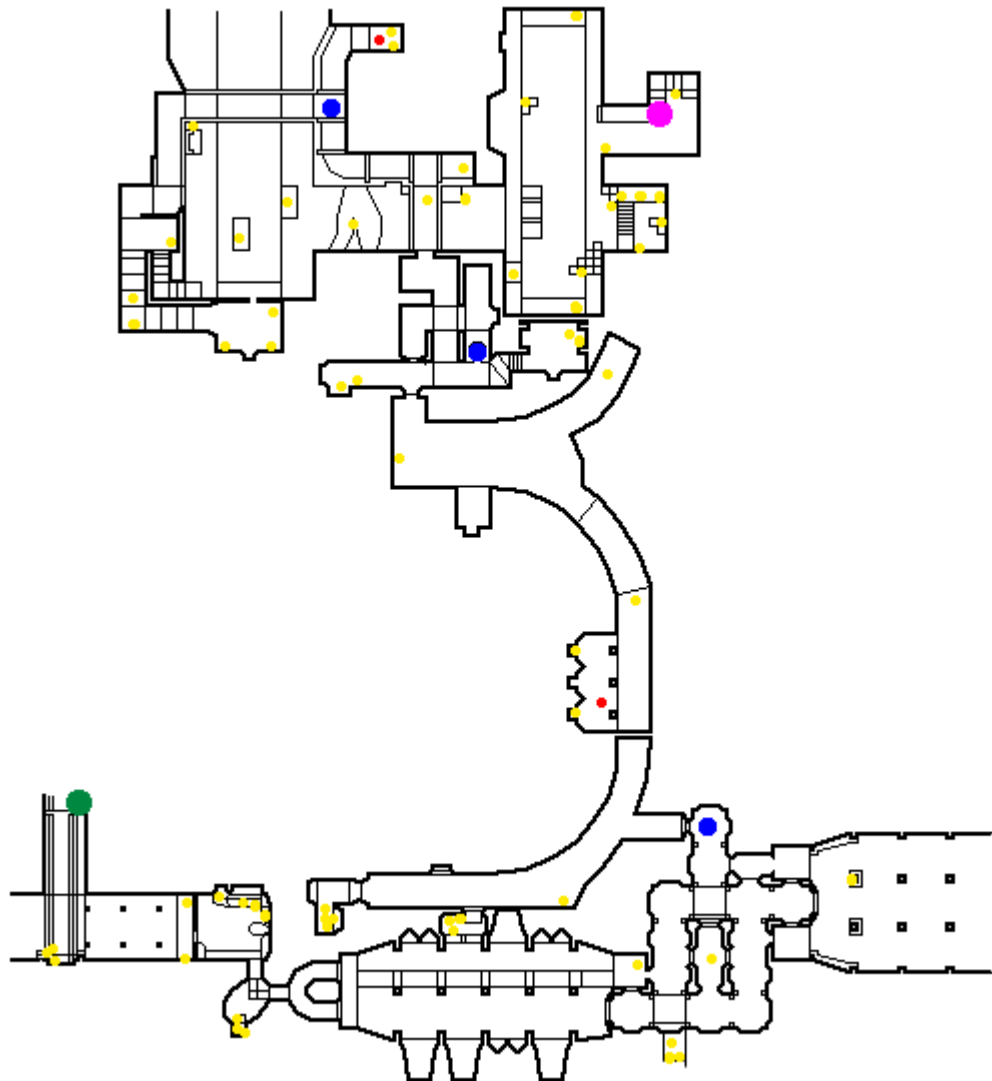



- **Start**
- **Arrival**
- **Inventory Item**
- **Checkpoint**
- Secret**
- **Card on enemy**



Level :	7-1	Menu :	The Factory	Character :	Korben
---------	-----	--------	-------------	-------------	--------

Inventory item :	Electrogun		
Enemies :	Mangalore with machine gun	Sewer alien	Big sewer monster





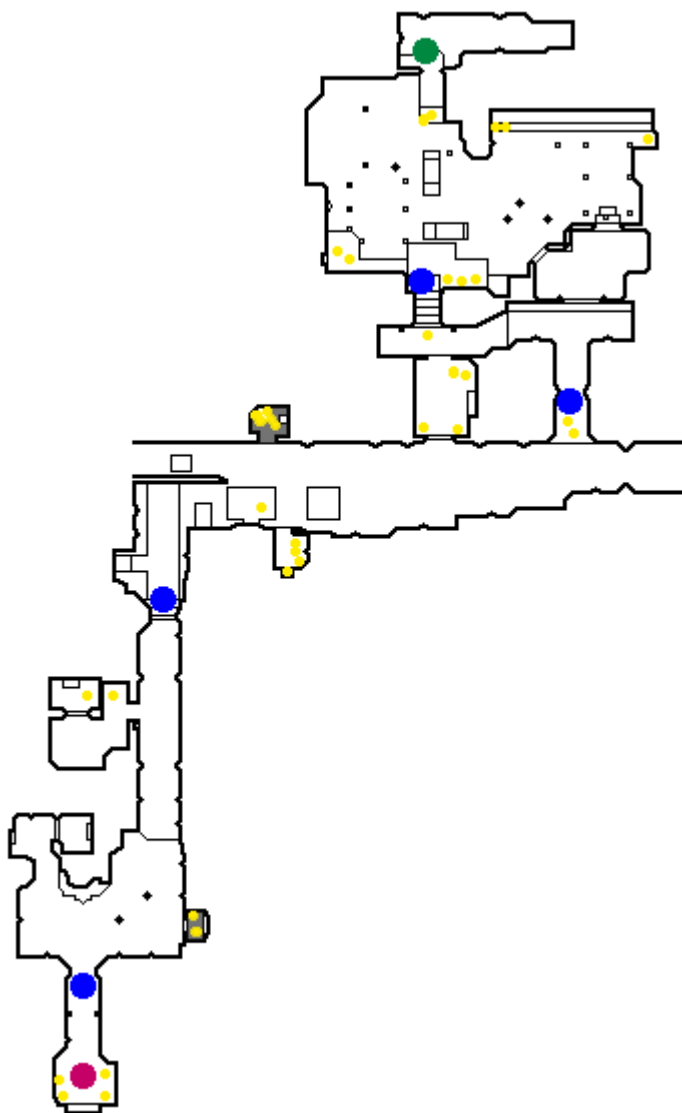

Mission : Leeloo and Korben have escaped from the New York police by hiding in an disused factory in which Korben must locate a taxi while Leeloo looks for the Water element.

 Start	 Arrival	 Inventory Item	 Checkpoint	 Secret
		 Card on ennemy		



Level :	7-2	Menu :	The Factory	Character :	Leeloo
Inventory item :	Element water				
Enemies :	Green sewers monster	Sewers alien	Big sewer monster		





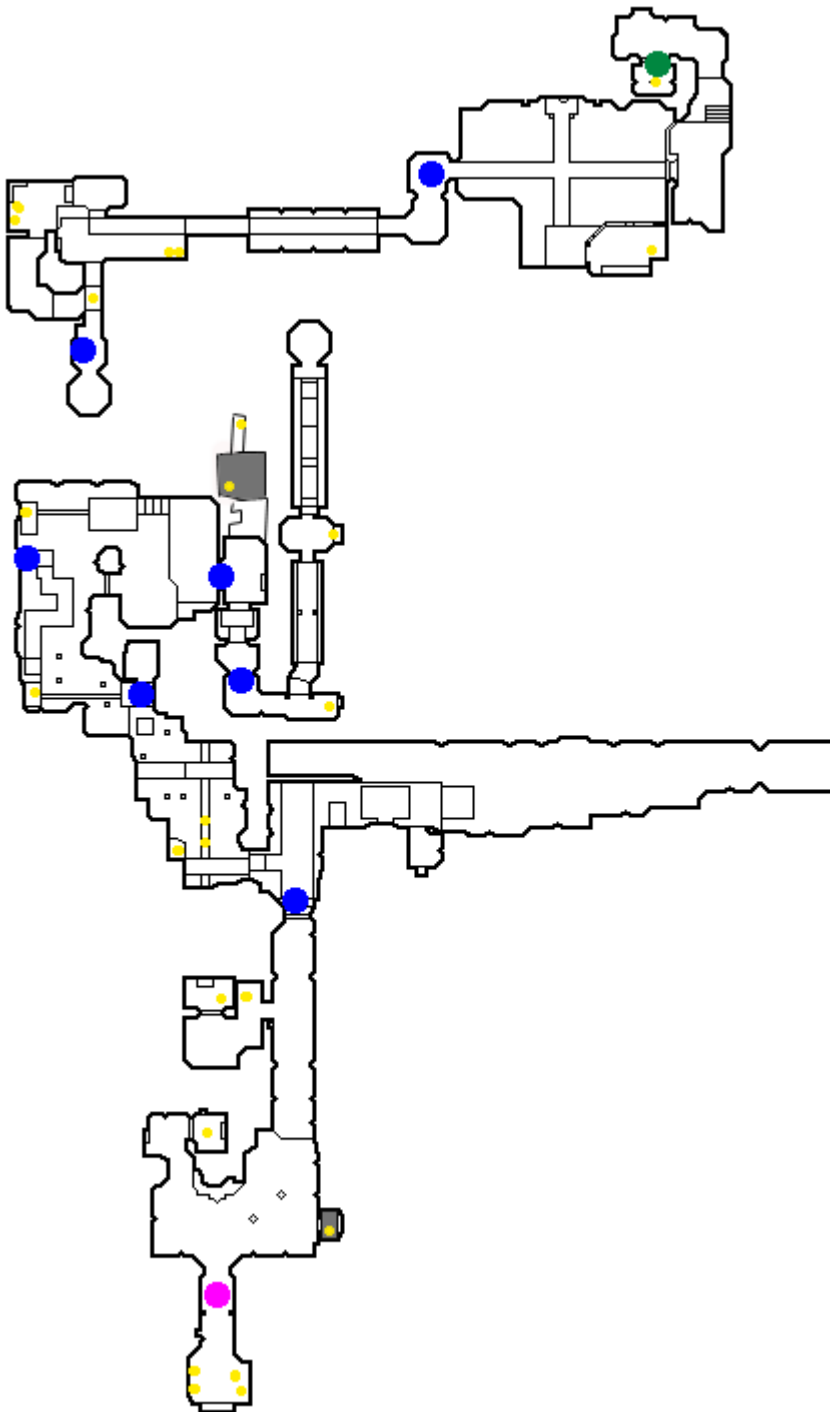

Mission : Leeloo and Korben have escaped from the New York police by hiding in an disused factory in which Korben must locate a taxi while Leeloo looks for the Water element.

 Start	 Arrival	 Inventory Item	 Checkpoint	 Secret
		 Card on ennemy		



Level :	8-1	Menu :	Astroport	Character :	Korben
Inventory item :	Water activator	1 card on ennemi			
Enemies :	Black cop with gun	Mangalore with machine gun	Flying cop		





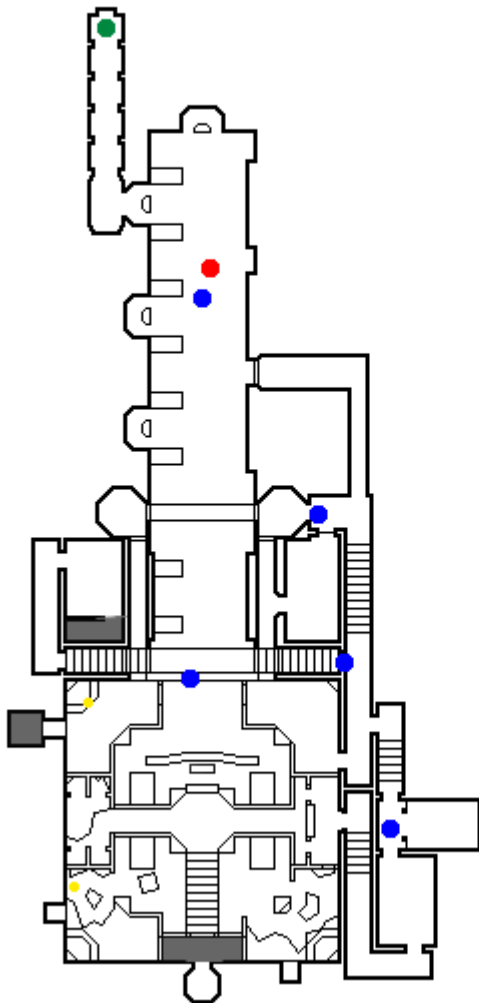

Mission : Leeloo and Korben must now find a way into the Astroport. Once inside they must look for the space shuttle and Korben must find the Water activator.

 Start	 Arrival	 Inventory Item	 Checkpoint	 Secret
		 Card on ennemy		



Level :	8-2	Menu :	<i>Astroport</i>	Character :	<i>Leelo</i>
Inventory item :	<i>1 card on ennemi</i>				
Enemies :	<i>Cop with truncheon</i>	<i>Hand fighting Mangalore</i>	<i>Flying Cop</i>		

Mission : *Leelo and Korben must now find a way into the Astroport. Once inside they must look for the space shuttle and Korben must find the Water activator.*



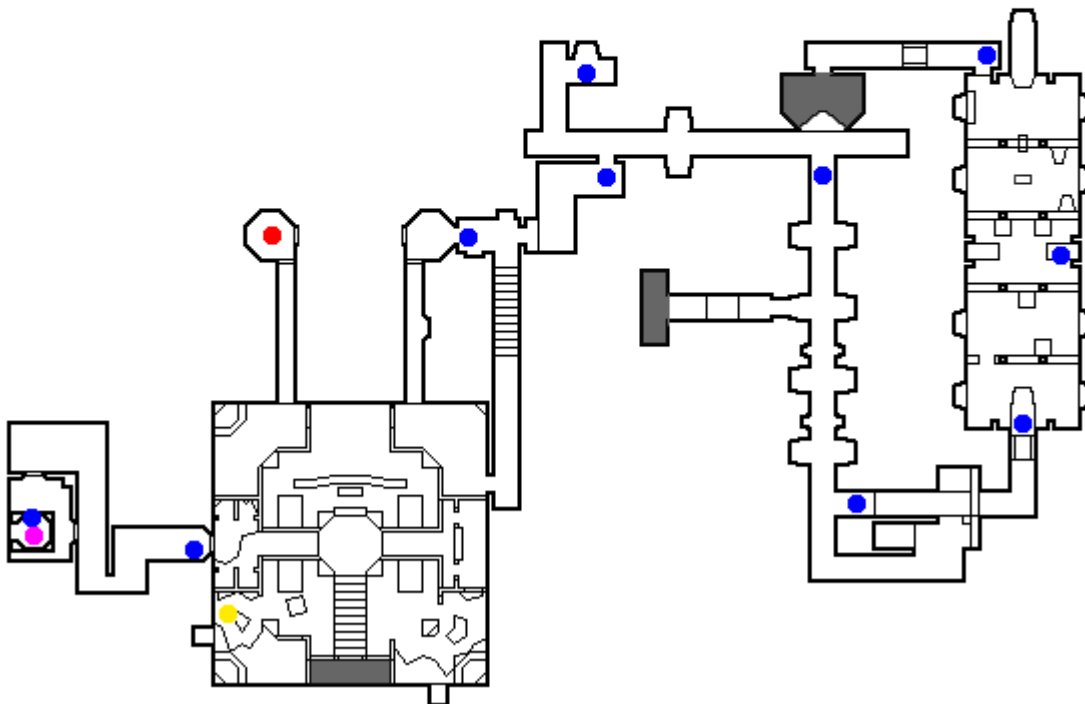
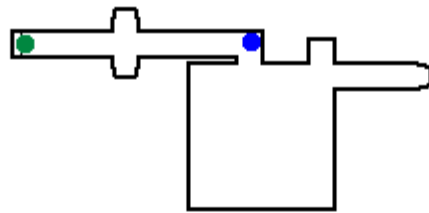



 Start	 Arrival	 Inventory Item	 Checkpoint	 Secret
		 Card on enemy		



Level :	9	Menu :	Call from Zorg	Character :	Korben
---------	---	--------	----------------	-------------	--------

Inventory item :			
Enemies :			

Mission : *The telephone boxes in the Astroport have been boobytrapped by the evil Zorg. Korben must secure the area by destroying the phones that successively ring. You must do this quickly, very quickly!*



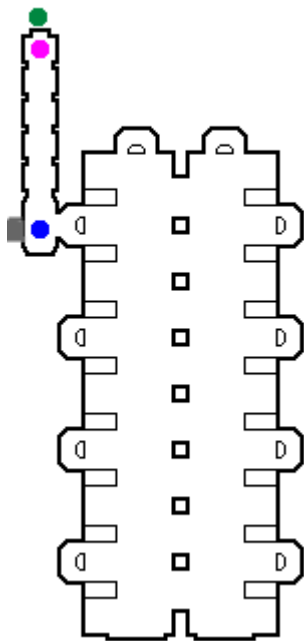



 Start	 Arrival	 Inventory Item	 Checkpoint	 Secret
		 Card on ennemy		



Level :	<i>10-1</i>	Menu :	<i>Fhloston flight</i>	Character :	<i>Korben</i>
----------------	-------------	---------------	------------------------	--------------------	---------------

Inventory item :	<i>1 card on ennemi</i>		
Enemies :	<i>Hand fighting Mangalore</i>	<i>Mangalore with 2 guns</i>	<i>Mangalore with machine gun</i>

Mission : *Korben and Leeloo have succeeded in getting onto the shuttle for Fhloston Paradise but the Mangalores have stopped the engines and taken the pilots hostage. Leeloo must save them by liberating the cockpit while Korben reactivates the engines in the machine room.*



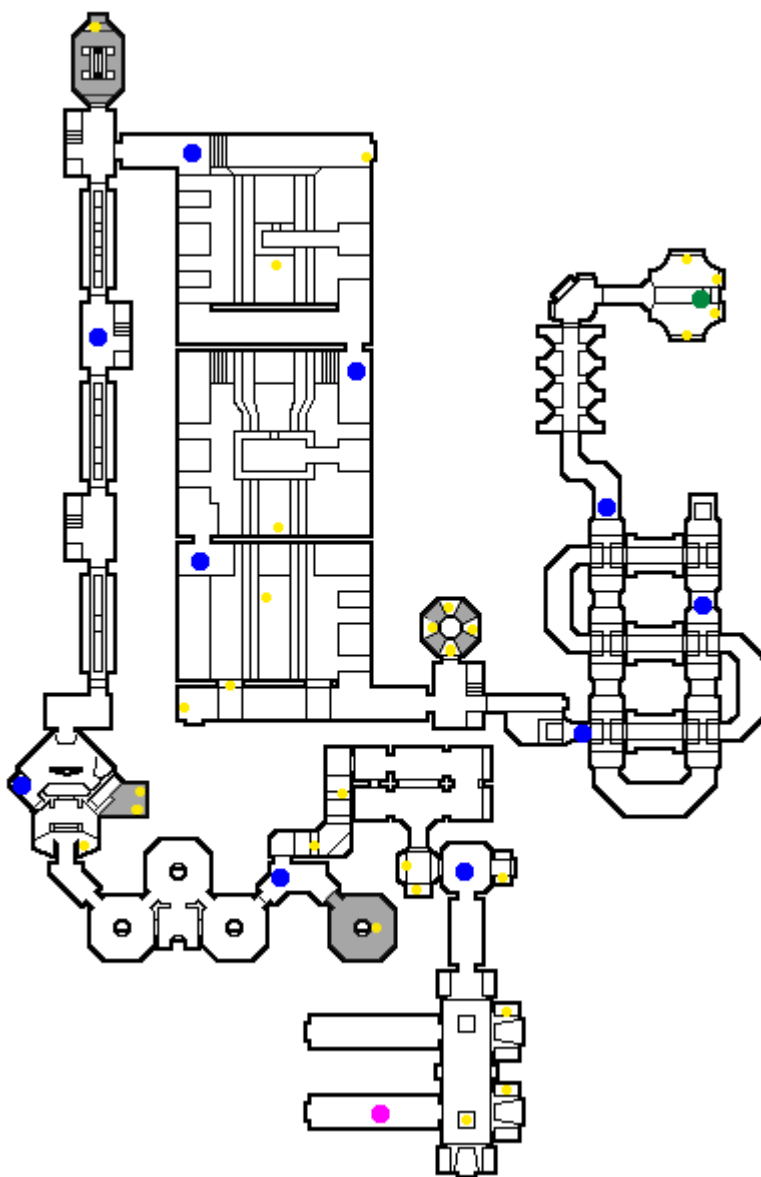



 Start	 Arrival	 Inventory Item	 Checkpoint	 Secret
		 Card on ennemy		



Level :	<i>10-2</i>	Menu :	<i>Fhloston flight</i>	Character :	<i>Leeloo</i>
----------------	-------------	---------------	------------------------	--------------------	---------------

Inventory item :	<i>1 card on ennemi</i>		
Enemies :	<i>Hand fighting Mangalore</i>	<i>Mangalore with 2 guns</i>	<i>Mangalore with machine gun</i>

Mission : *Korben and Leeloo have succeeded in getting onto the shuttle for Fhloston Paradise but the Mangalores have stopped the engines and taken the pilots hostage. Leeloo must save them by liberating the cockpit while Korben reactivates the engines in the machine room.*



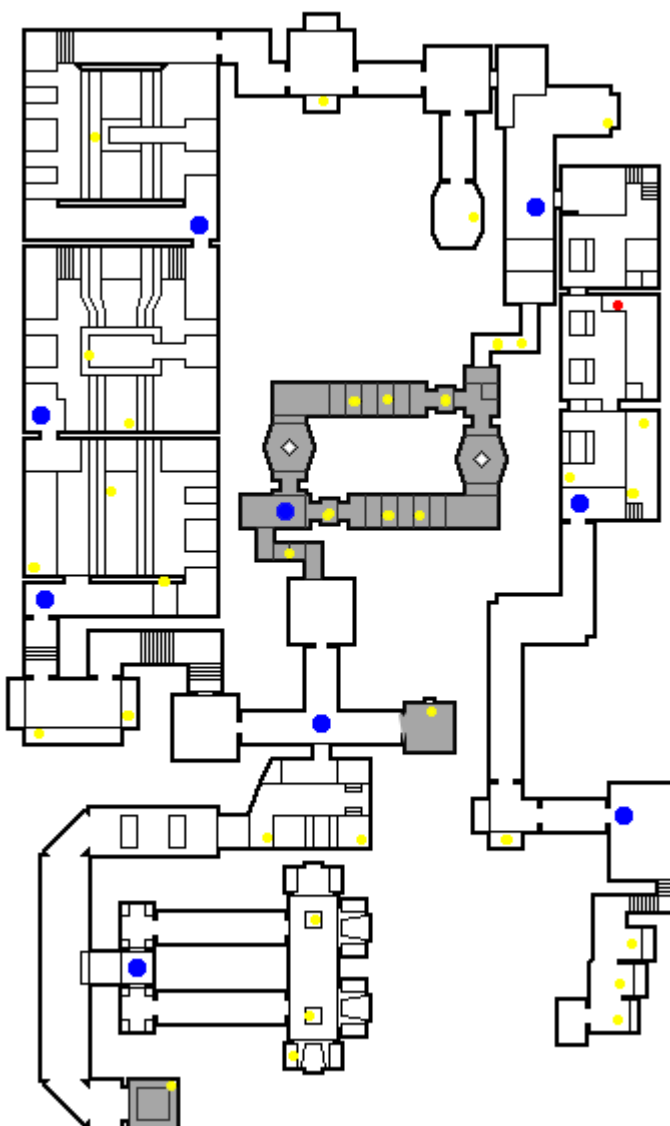



 Start	 Arrival	 Inventory Item	 Checkpoint	 Secret
		 Card on ennemy		



Level :	11-1	Menu :	Fhloston Paradise	Character :	Korben
---------	------	--------	-------------------	-------------	--------

Inventory item :	Zorg Card	ZF1	
Enemies :	Mangalore with machine gun	Zorg's man with gun	Zorg with the ZF1

Mission : *Zorg and the Mangalores have arrived and are wreaking panic on Fhloston Paradise. Zorg plans to destroy the sumptuous vessel as soon as he has gathered the stones. Korben must follow him to get the card to deactivate the bombs while Leeloo looks for the Air element that is hidden in the vessel.*



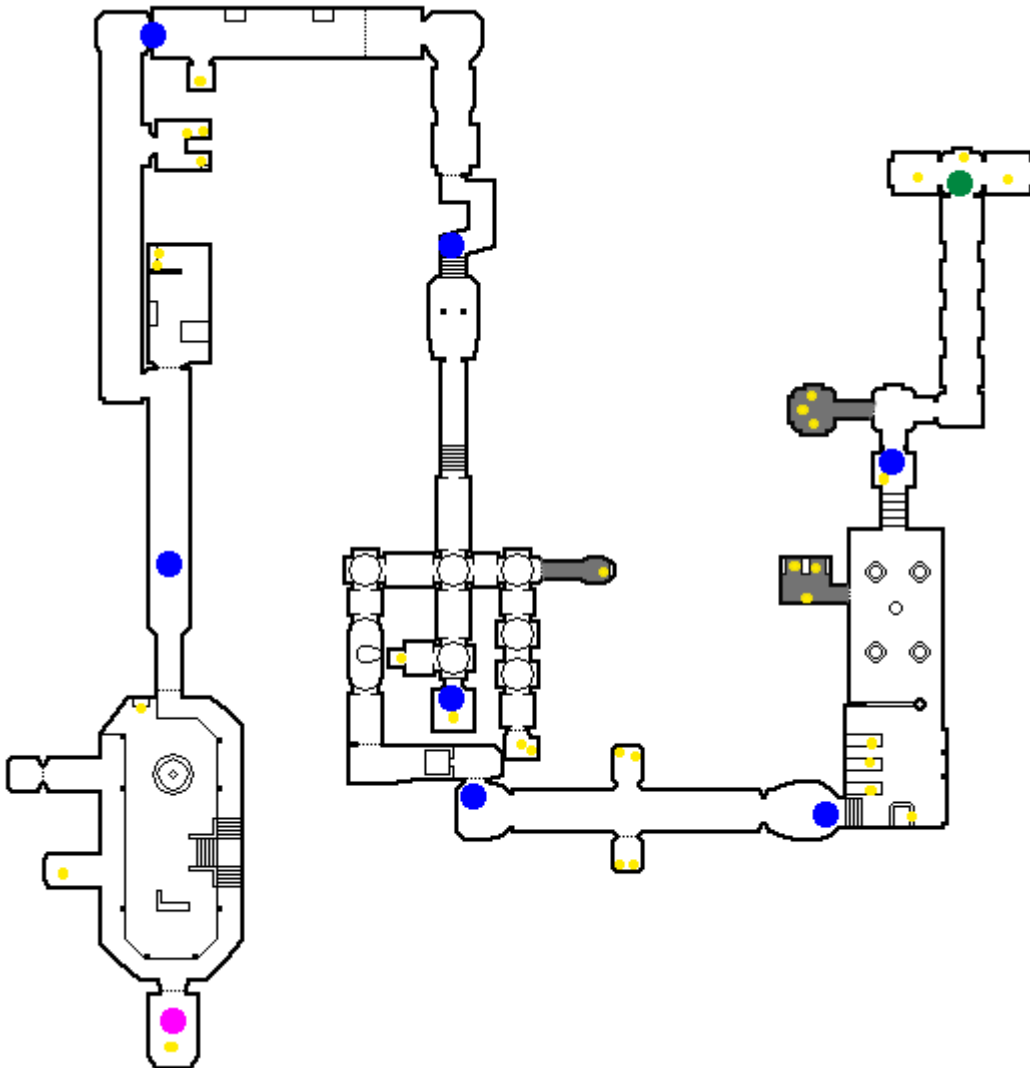



 Start	 Arrival	 Inventory Item	 Checkpoint	 Secret
		 Card on ennemy		



Level :	11- 2	Menu :	Fhloston Paradise	Character :	Leeloo
---------	----------	--------	-------------------	-------------	--------

Inventory item :	Element air		
Enemies :	Black Zorg's man	White Zorg's man	Hand fighting Mangalore

Mission : *Zorg and the Mangalores have arrived and are wreaking panic on Fhloston Paradise. Zorg plans to destroy the sumptuous vessel as soon as he has gathered the stones. Korben must follow him to get the card to deactivate the bombs while Leeloo looks for the Air element that is hidden in the vessel.*



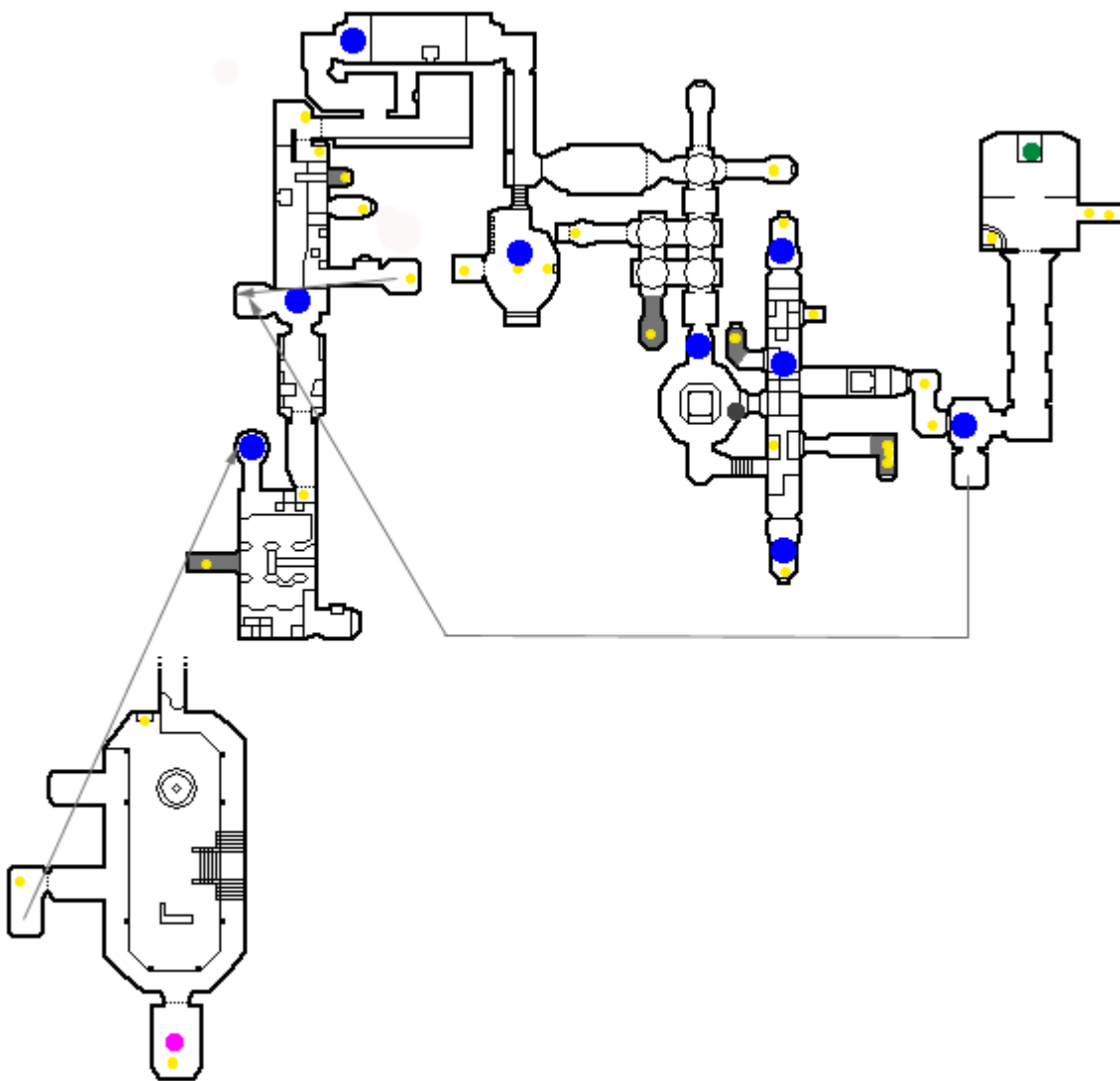



 Start	 Arrival	 Inventory Item	 Checkpoint	 Secret
		 Card on ennemy		



Level :	12-1	Menu :	Machine room	Character :	Korben
---------	------	--------	--------------	-------------	--------

Inventory item :	ZFX Energy cells	3 cards on ennemies	
Enemies :	Zorg's man with gun	Black Zorg's man	Spider

Mission : *There is not much time left as Ultimate Evil is now near Earth. Korben must find an energy cell to start a rescue shuttle to escape Fhloston Paradise. Leeloo continues to search for the elements, now looking for the fire stone.*



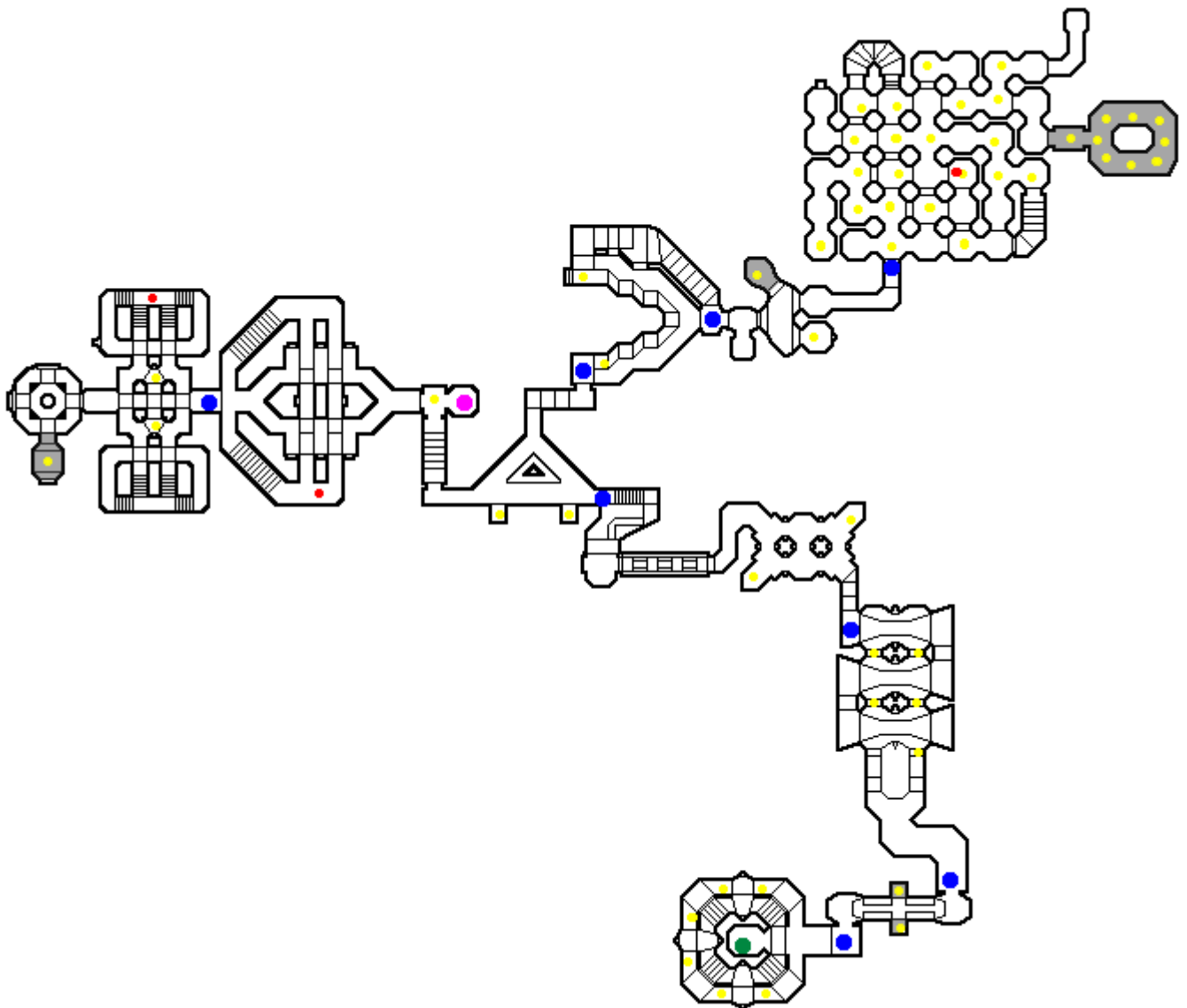



 Start	 Arrival	 Inventory Item	 Checkpoint	 Secret
		 Card on ennemy		



Level :	12- 2	Menu :	Machine room	Character :	Leeloo
---------	----------	--------	--------------	-------------	--------

Inventory item :	Element fire	3 cards on ennemies	
Enemies :	Zorg's man with gun	Black Zorg's man	Spider

Mission : *There is not much time left as Ultimate Evil is now near Earth. Korben must find an energy cell to start a rescue shuttle to escape Fhloston Paradise. Leeloo continues to search for the elements, now looking for the fire stone.*

 Start	 Arrival	 Inventory Item	 Checkpoint	 Secret
		 Card on enemy		

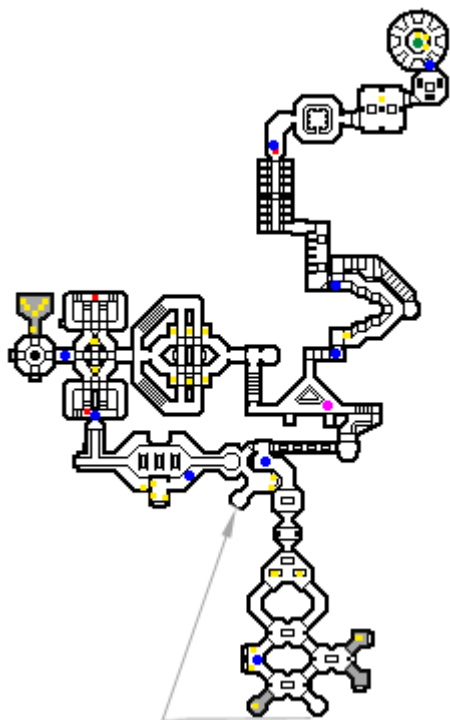

Level :	13	Menu :	Free Cornelius	Character :	Korben
---------	----	--------	----------------	-------------	--------

Inventory item :	4 cards on ennemies		
Enemies :	Mangalore with 2 guns	Mangalore with machine gun	

Mission : *The Mangalores have attacked the Fhloston security centre and taken Cornelius hostage in order to recover the stones. They have put Cornelius in the reactor and Korben has 5 minutes to save him and stop the reactor before he dies!*



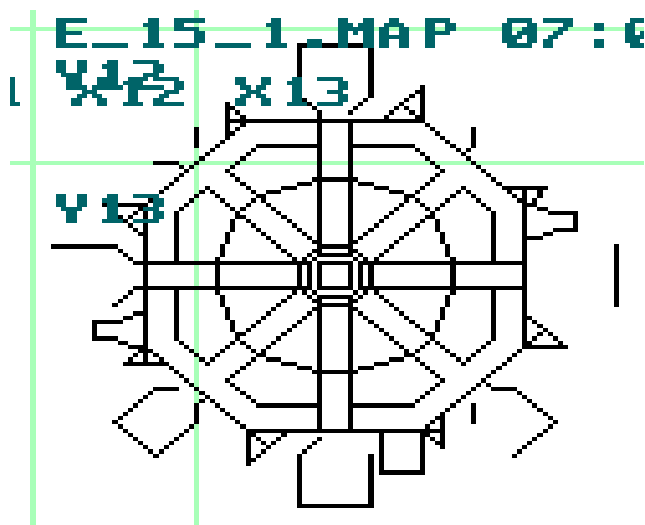



-
- Start
 - Arrival
 - Inventory Item
 - Checkpoint
 - Secret
 - Card on ennemy
-



Level :	<i>14-1</i>	Menu :	<i>Bomb alert</i>	Character :	<i>Korben</i>
----------------	-------------	---------------	-------------------	--------------------	---------------

Inventory item :			
Enemies :	<i>Hand fighting Mangalore</i>	<i>Mangalore with 2 guns</i>	<i>Mangalore with machine gun</i>

Mission : *Zorg is implementing his fiendish plan by boobytrapping the Opera with a time bomb. Korben must activate the electronic posts hidden in the building in order to delay the countdown and then find a rescue shuttle to escape! Before escaping with Korben, Leeloo must get the Mondoshawan key and the Air activator for the Egyptian temple.*



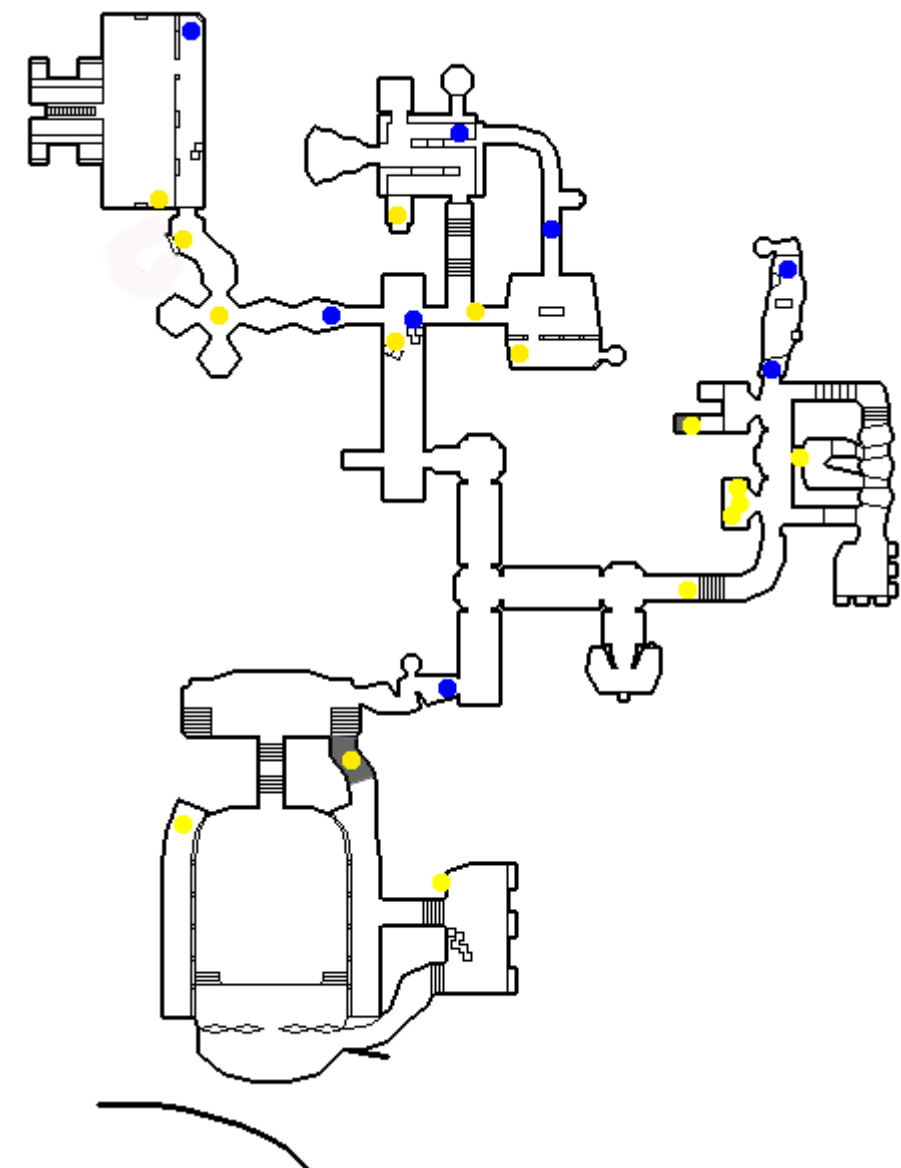



 Start	 Arrival	 Inventory Item	 Checkpoint	 Secret
		 Card on ennemy		



Level :	<i>14-2</i>	Menu :	<i>Bomb alert</i>	Character :	<i>Leeloo</i>
----------------	-------------	---------------	-------------------	--------------------	---------------

Inventory item :	<i>Mondoshawan key</i>	<i>Air activator</i>	<i>1 card on ennemi</i>
Enemies :	<i>Hand fighting Mangalore</i>	<i>Mangalore with 2 guns</i>	<i>Mangalore with machine gun</i>

Mission : *Zorg is implementing his fiendish plan by boobytrapping the Opera with a time bomb. Korben must activate the electronic posts hidden in the building in order to delay the countdown and then find a rescue shuttle to escape! Before escaping with Korben, Leeloo must get the Mondoshawan key and the Air activator for the Egyptian temple.*



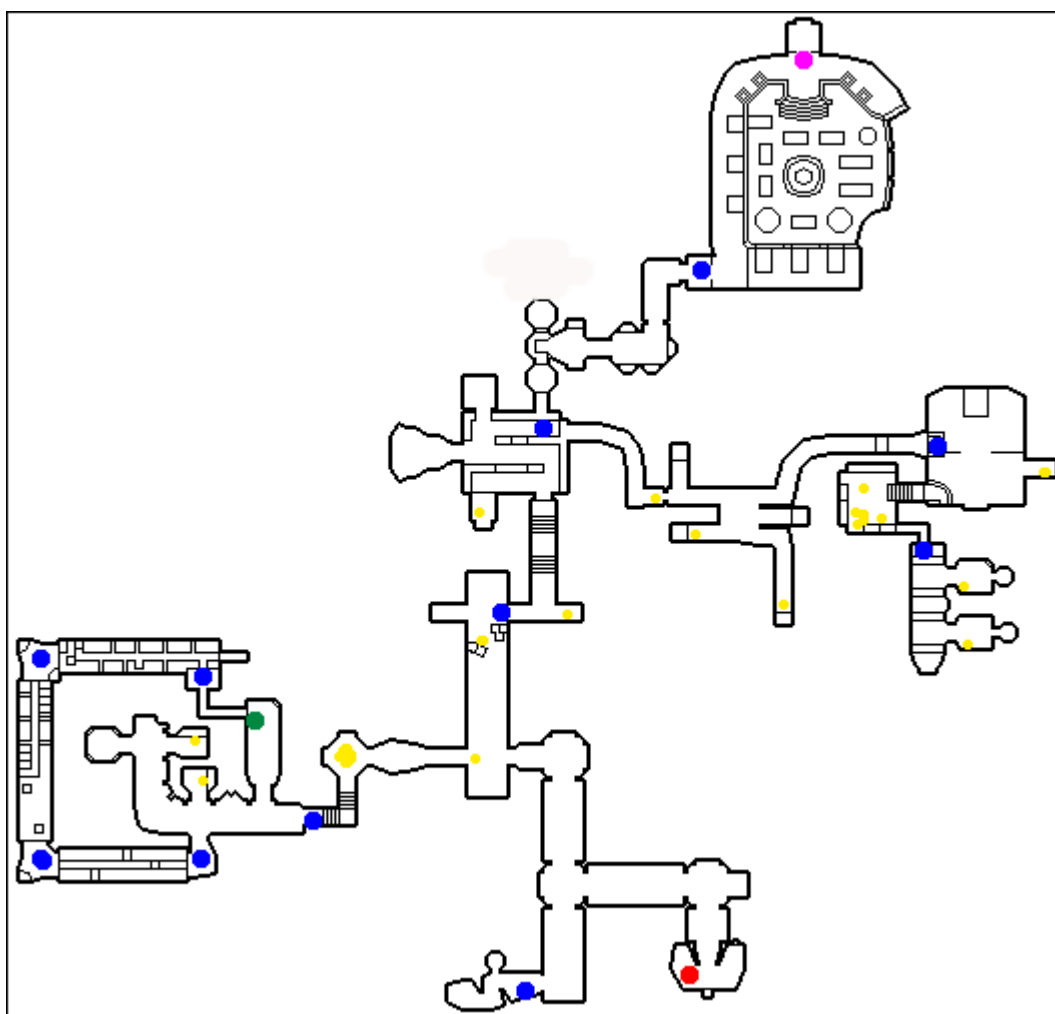



 Start	 Arrival	 Inventory Item	 Checkpoint	 Secret
		 Card on ennemy		



Level :	15-1	Menu :	Egyptian temple	Character :	Korben
---------	------	--------	-----------------	-------------	--------

Inventory item :			
Enemies :	Mangalore with machine gun	Egyptian robot	Egyptian enemi

Mission : Arriving in Egypt, Leeloo leaves in search of the last sacred stone, the Earth element. Once she has the four elements Leeloo must enter the sarcophagus room accessed with the Mondoshawan key. Korben must find the secret stones to the temple and activate them. Only then can he finally activate the elements and save the planet from Absolute Evil.



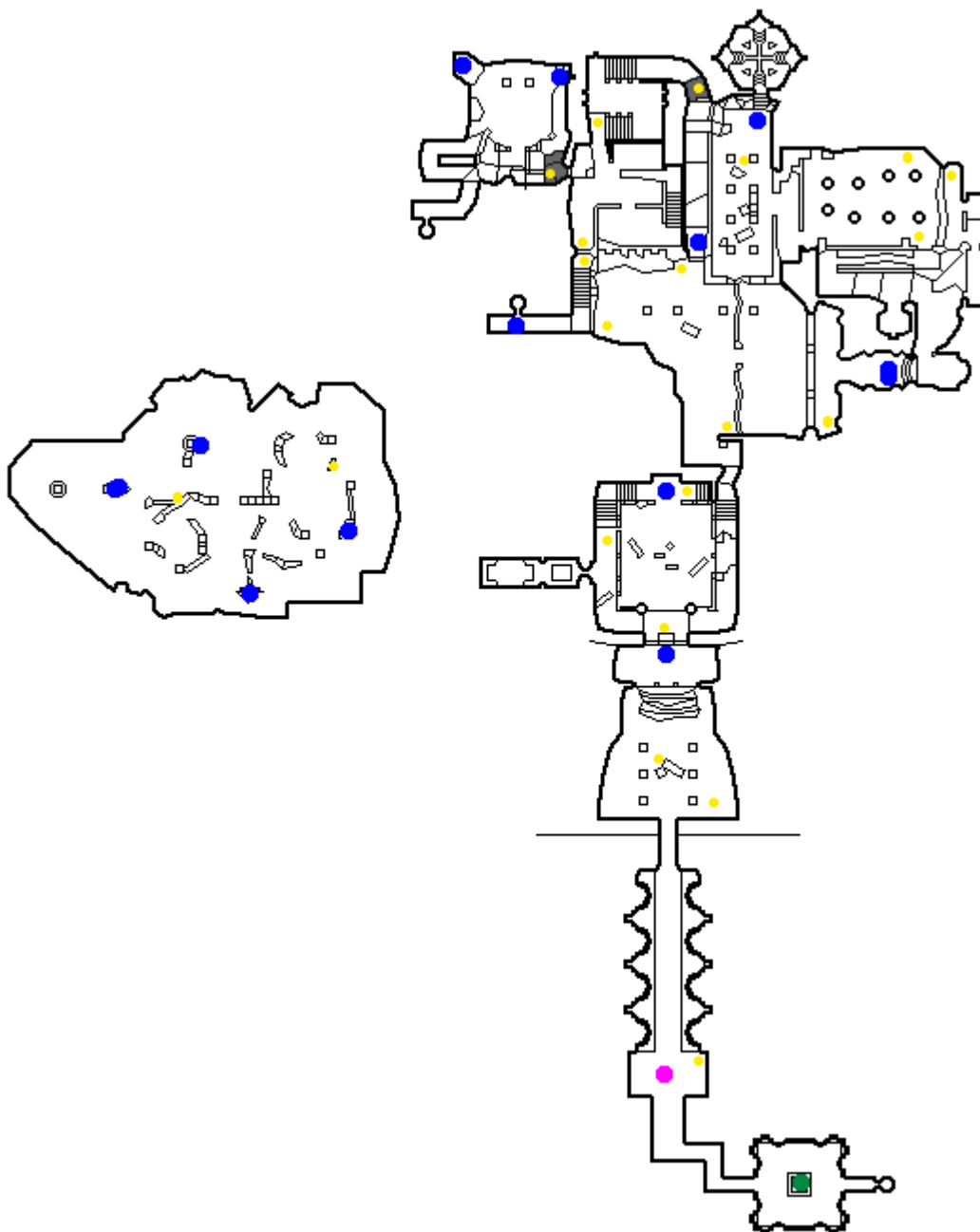



 Start	 Arrival	 Inventory Item	 Checkpoint	 Secret
		 Card on ennemy		



Level :	15-2	Menu :	Egyptian temple	Character :	Leeloo
---------	------	--------	-----------------	-------------	--------

Inventory item :	Element earth		
Enemies :	Hand fighting Mangalore	Egyptian robot	Egyptian enemi

Mission : Arriving in Egypt, Leeloo leaves in search of the last sacred stone, the Earth element. Once she has the four elements Leeloo must enter the sarcophagus room accessed with the Mondoshawan key. Korben must find the secret stones to the temple and activate them. Only then can he finally activate the elements and save the planet from Absolute Evil.

 Start	 Arrival	 Inventory Item	 Checkpoint	 Secret
		 Card on ennemy		

